

# Stûv B-150 | The stove

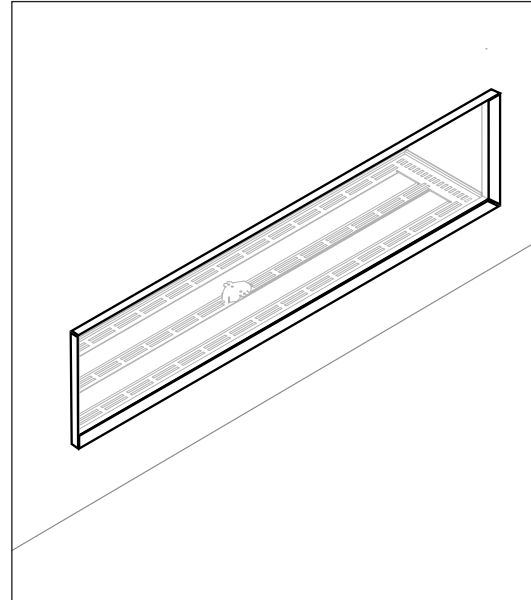

<b>Enjoyment of the fire</b>	Double burner
<b>Aesthetics and easy integration</b>	Gas insert available in multiple formats (one-sided, two-sided) Choice of interiors (cailloux, bûches céramiques, dos en verre)
<b>Ease of use</b>	Option to turn on 1 or 2 burners and set the height of the flame Standard remote control Optional mobile app
<b>Energy saving</b>	Eco wave programme that cycles gas supply levels



## TECHNICAL OVERVIEW

GENERAL	
TYPE OF STOVE	C11 / C31
MATERIALS	steel
COLOUR	anthracite
FUEL	Natural gas
WEIGHT / SIZE	
WEIGHT	160kg
Ø OF SMOKE FLUE OUTLET	130-200mm

ACCESSORIES / EQUIPMENT	
REMOTE CONTROL	✓
HANDSET WIFI	○
'WOOD BURNER'	✗
CONVECTION CASING	○
BACK PANEL	
· BLACK STEEL	✓
· BLACK GLASS	○
· PIET BOON IRON STRIPS	✗
DECORATIVE OPTIONS	
· SET OF LOGS	✓
· ANTHRACITE STONES	○
· WHITE STONES	○
ANTI-REFLECTIVE GLASS	○
AC 220V ADAPTOR	✓

Conforms to the standard EN 613:2000

LEGEND	
✓	YES
✗	NO
○	OPTION

## Stûv B-150 | Technical specifications



## TYPE C11 / C31

GAS TYPE		<b>G20</b>	<b>G20 / G25</b>	<b>G25.3</b>	<b>G31</b>	<b>G31</b>	<b>G31</b>
		I2H, I2E, I2E+	I2ELL	I2EK	I3P (30)	I3P (37)	I3P (50)
SUPPLY PRESSURE	mbar	20	20	25	30	37	50
NOMINAL HEAT INPUT GROSS (HS)	kW	19	19		15	15	15
OUTPUT	kW	13,8	13,8	13,8	10,6	10,6	10,6
CONSUMPTION	m <sup>3</sup> /h	1,77	1,77	1,88	/	/	/
CONSUMPTION	Kg/h	/	/	/	1,045	1,045	1,045
BURNER PRESSURE (HOT)	mbar	5,5	5,5		22	22	22
INJECTOR MARKING		1200 (7 holes)	1200 (7 holes)	1200 (7 holes)	280 (1 hole)	280 (1 hole)	280 (1 hole)
PILOT		0.160.032-51	0.160.032-51	0.160.032-51	0.160.032-31	0.160.032-31	0.160.032-31
EFFICIENCY CLASS*		2	2	2	2	2	2
Nox CLASS		4	4	4	4	4	4
ENERGY EFFICIENCY INDEX (EEI)		77	77	77	77	77	77
ENERGY EFFICIENCY CLASS		<b>C</b>	<b>C</b>	<b>C</b>	<b>C</b>	<b>C</b>	<b>C</b>

\* Class 1: efficiency over 82%. Class 2: efficiency between 65% and 82%.

# Stûv B-150 | Dimensions



## Single-sided version

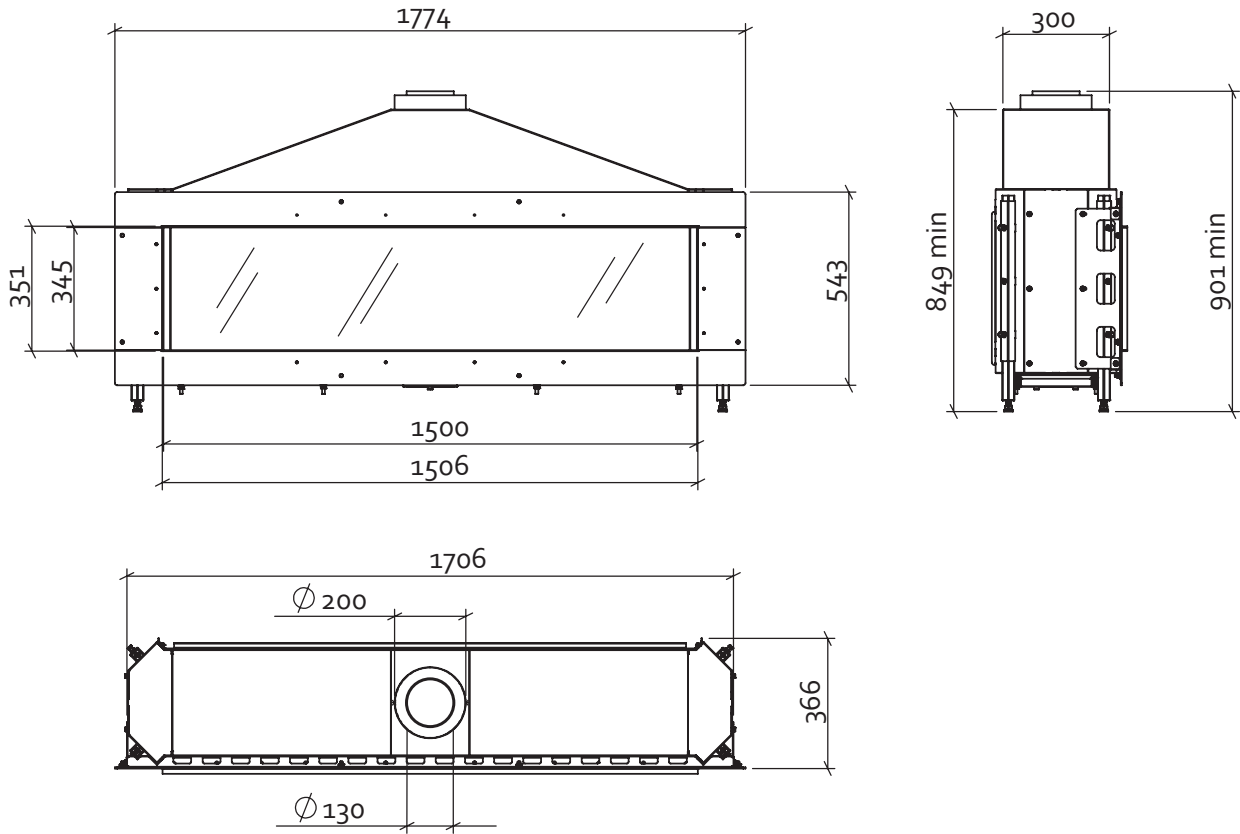

# Stûv B-150 | Dimensions



## Double-sided version

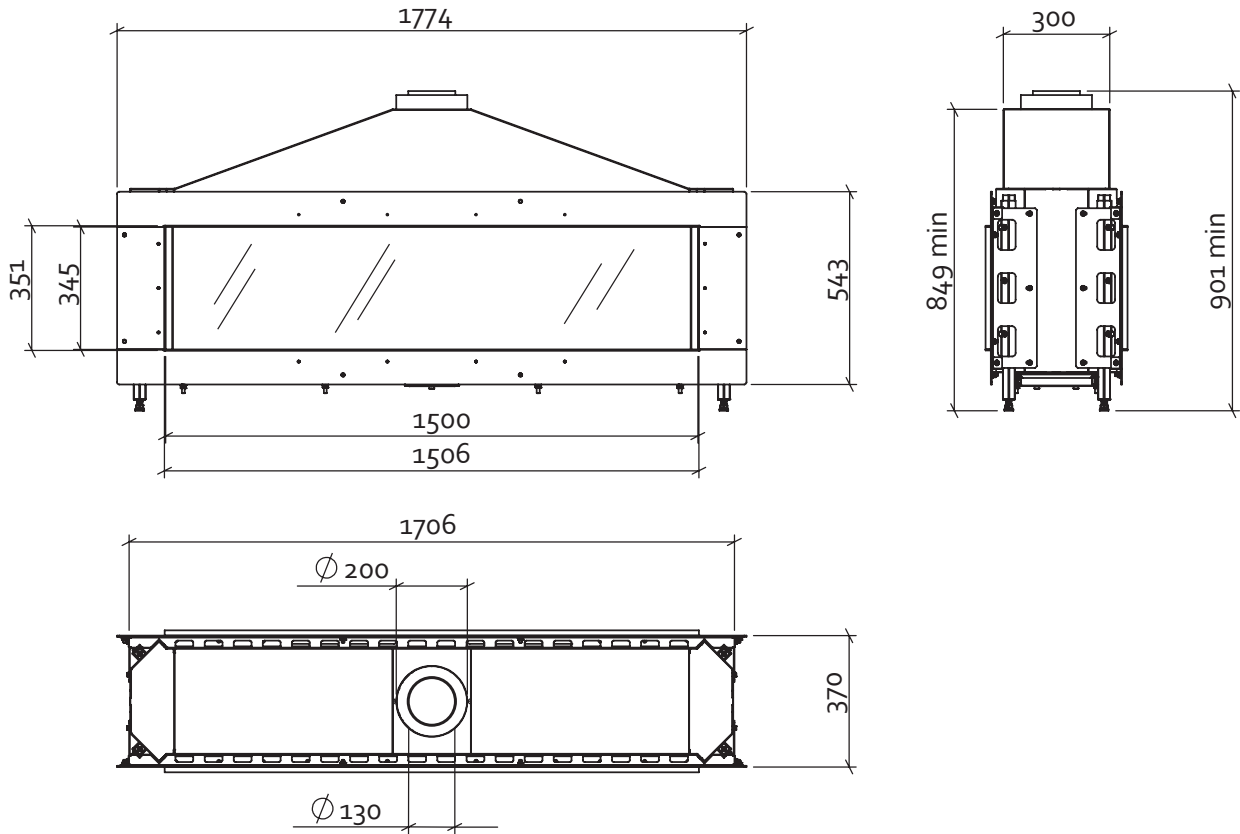

## Frame Under-Cover UC 150 Piet Boon

---

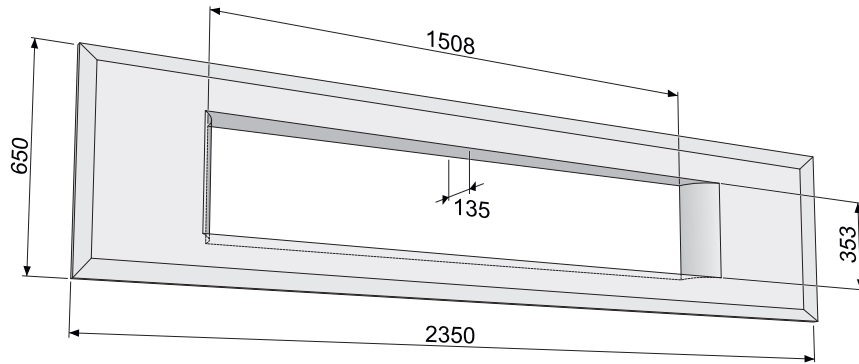

## CONVECTION CASING

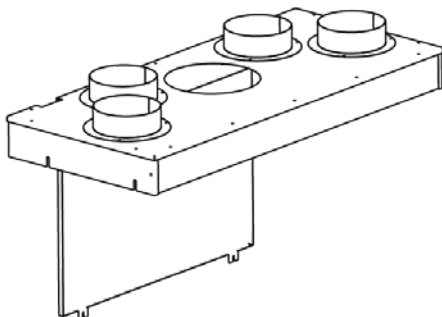

## TRAPDOOR



## AC ADAPTER 220V



## REMOTE CONTROL



## WIFI HANDSET

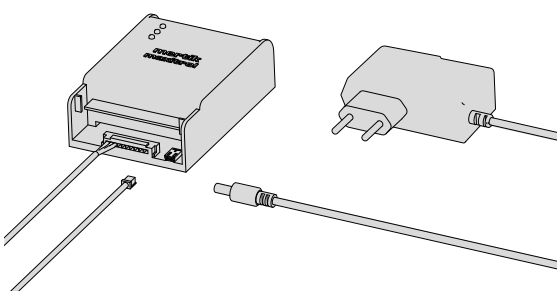

## HOME AUTOMATION CABLE



## ANTI-REFLECTIVE GLASS



DIMENSIONS INSPECTION PANEL (STEEL)

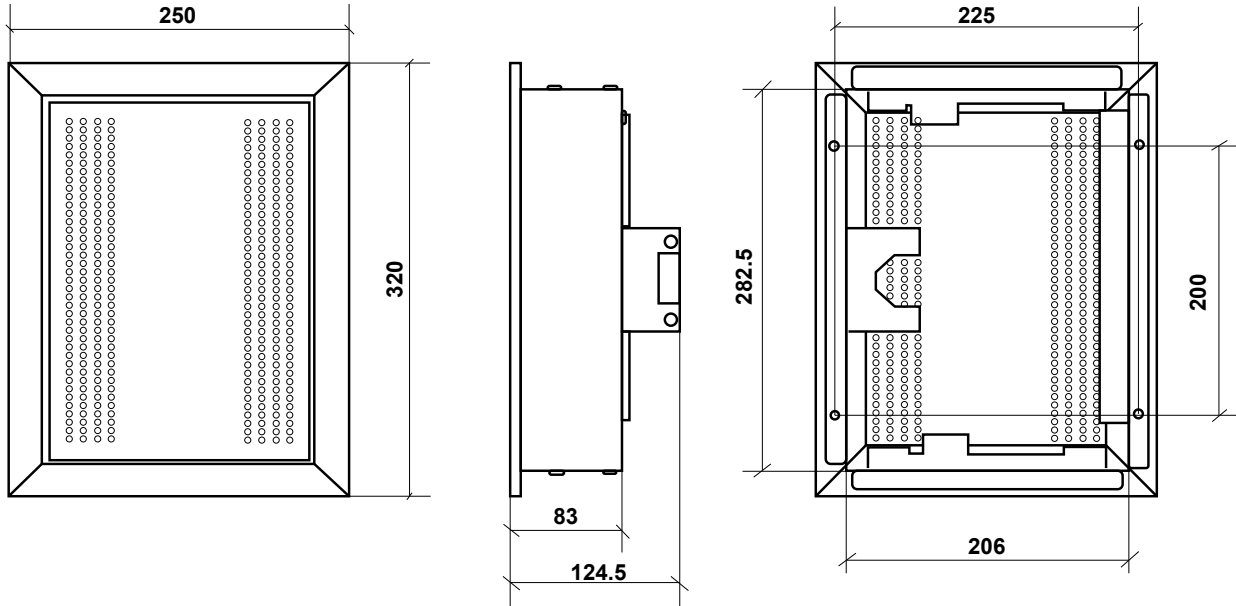

DIMENSIONS INSPECTION PANEL (UNDERCOVER)

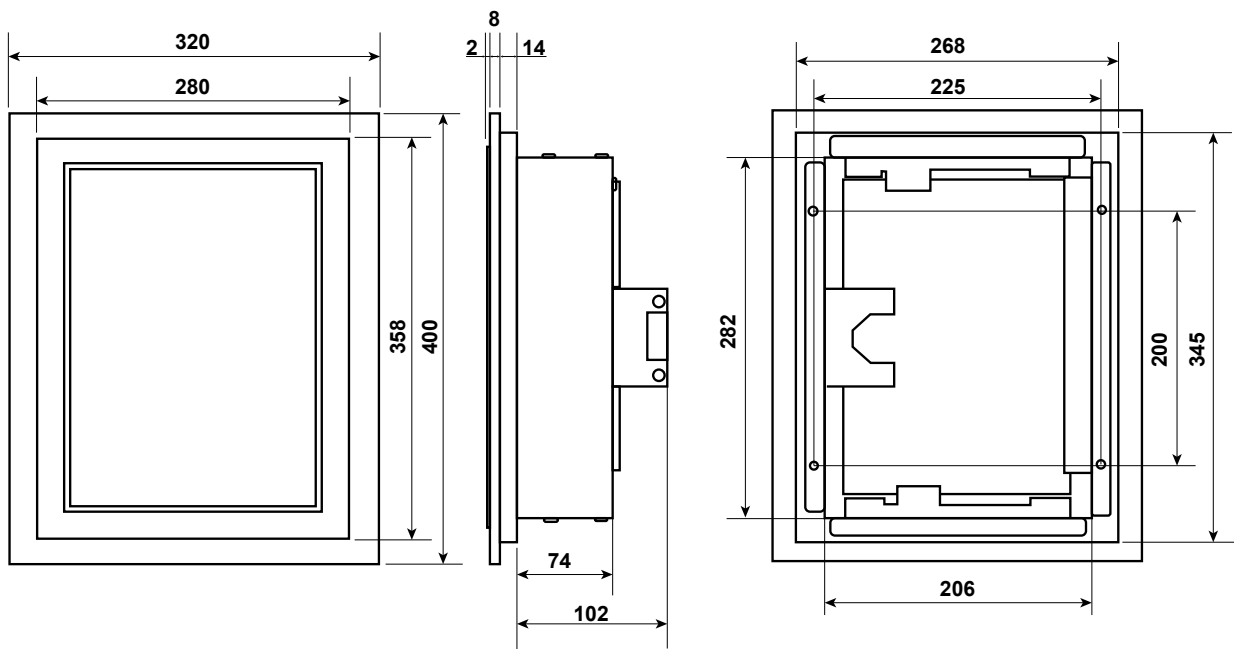

# Stûv Gas fire | Mode of operation



· Stûv gas fires are designed to be connected to a concentric stainless steel balanced flue system. The fires are room sealed and take the oxygen required for combustion through the outer wall of the flue system. The heat from the products of combustion being expelled by the centre pipe warms the incoming air in the outer pipe too.

· Stûv gas fires are able to be ordered for LPG too, please specify this with your retailer at point of order. The flame visuals, output and efficiency are different when using LPG.

· Stûv gas fires can be installed with an optional convection casing which can be used to capture and channel the convected heat.